

Features

- High Blocking Voltage with Low On-Resistance
- High Speed Switching with Low Capacitances
- Avalanche Ruggednes

Applications

- Solar Inverters
- Switch Mode Power Supplies
- High Voltage DC-DC Converters
- Battery Chargers

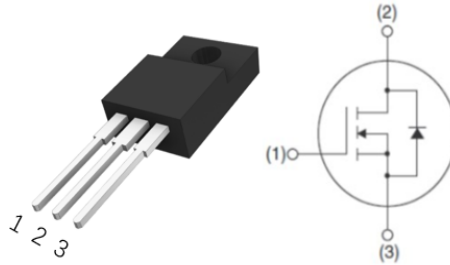

Product Summary

V_{DS}	800V
$R_{DS(on)}_{typ}$	280mΩ
I_D	13.3A



Package Marking and Ordering Information

Part #	Marking	Package
MX280080F	MX280080F	TO220F

Absolute Maximum Ratings

Parameter	Symbol	Value	Unit
Drain-source voltage	V_{DS}	800	V
Continuous drain current $T_C = 25^\circ\text{C}$, $V_{GS} = 18\text{V}$ $T_C = 125^\circ\text{C}$, $V_{GS} = 18\text{V}$	I_D	13.3 7.7	A
Source current(Body Diode) $T_C = 25^\circ\text{C}$, $V_{GS} = -4\text{V}$ $T_C = 125^\circ\text{C}$, $V_{GS} = -4\text{V}$	I_S	13.3 7.7	A
Pulsed drain current ($T_C = 25^\circ\text{C}$, t_p limited by T_{jmax})	I_{DM}	45	A
Avalanche energy, single pulse ($L=10\text{mH}$)	E_{AS}	180	mJ
Gate-Source voltage	V_{GS}	-4/+18	V
Gate-Source voltage (Absolute maximum values)	V_{GSmax}	-8/+22	V
Power dissipation ($T_C = 25^\circ\text{C}$)	P_{tot}	50	W
Operating junction and storage temperature	T_j, T_{stg}	-55...+175	$^\circ\text{C}$

- Example of acceptable V_{GS} waveform



Thermal Resistance

Parameter	Symbol	Value	Unit
Thermal resistance, junction – case. Max	R_{thJC}	3.0	°C/W
Thermal resistance, junction – ambient. Max	R_{thJA}	40	

Electrical Characteristic (at $T_j = 25\text{ °C}$, unless otherwise specified)

Parameter	Symbol	Value			Unit	Test Condition
		min.	typ.	max.		

Static Characteristic

Drain-source breakdown voltage	V_{DSS}	800	-	-	V	$V_{GS}=0V, I_D=100\mu A$
Gate threshold voltage	$V_{GS(th)}$	2	3	4	V	$V_{DS}=V_{GS}, I_D=1mA$
Zero gate voltage drain current	I_{DSS}	-	1	5	μA	$V_{DS}=800V, V_{GS}=0V$ $T_C=25\text{ °C}$ $T_C=175\text{ °C}$
Gate-source leakage current	I_{GSS}	-	-	100	nA	$V_{GS}=18V, V_{DS}=0V$
Drain-source on-state resistance	$R_{DS(on)}$	-	280	330	mΩ	$V_{GS}=18V, I_D=3.6A,$ $T_J=25\text{ °C}$ $T_J=175\text{ °C}$
Drain-source on-state resistance	$R_{DS(on)}$	-	350	500	mΩ	$V_{GS}=15V, I_D=3.6A,$ $T_J=25\text{ °C}$ $T_J=175\text{ °C}$

Dynamic Characteristic

Input Capacitance	C_{iss}	-	271.0	-	pF	$V_{DS} = 800V$ $V_{GS} = 0V$ $T_J = 25\text{ °C}$ $V_{AC}=25mV$ $f = 1MHz$	
Output Capacitance	C_{oss}	-	19.8	-			
Reverse Transfer Capacitance	C_{rss}	-	1.8	-			
Gate Total Charge	Q_G	-	15.6	-	nC	$V_{DS} = 600V$ $V_{GS} = 0/+18V$ $I_D = 3.6A$ $I_G=10mA$	
Gate-Source charge	Q_{gs}	-	2.76	-			
Gate-Drain charge	Q_{gd}	-	7.86	-			
Turn-On Switching Energy	E_{ON}	-	52.1	-	μJ	$V_{DD} = 600V$ $V_{GS} = -4/+18V$ $I_D = 3.6A$ $R_G = 5\Omega$ $L = 1mH$ $T_J = 25\text{ °C}$	
Turn-Off Switching Energy	E_{OFF}	-	12.62	-			
Turn-on delay time	$t_{d(on)}$	-	4.2	-	ns		
Rise time	t_r	-	2	-			
Turn-off delay time	$t_{d(off)}$	-	10.2	-			
Fall time	t_f	-	9.8	-			
Gate resistance	R_G	-	3.0	-	Ω		$V_{AC} = 25mV, f=1MHz$

Body Diode Characteristic

Parameter	Symbol	Value			Unit	Test Condition
		min.	typ.	max.		
Body Diode Forward Voltage	V_{SD}	-	4.2	-	V	$V_{GS}=-4V, I_{SD}=1.8A,$ $T_J=25^{\circ}C$
		-	3.8	-		$V_{GS}=-4V, I_{SD}=1.8A,$ $T_J=175^{\circ}C$
Reverse Recovery Time	t_{rr}	-	22.2	-	ns	$V_R = 600V$ $I_D = 3.6A$ $di/dt = 1000A/\mu S$ $V_{GS} = -4V$ $T_J = 25^{\circ}C$
Reverse Recovery Charge	Q_{rr}	-	36	-	nC	
Reverse Recovery Energy	E_{REC}	-	14.74	-	uJ	
Peak Reverse Recovery Current	I_{rrm}	-	2.67	-	A	
Charge Time	t_A	-	10.8	-	ns	
DisCharge Time	t_B	-	11.4	-	ns	

Typical Performance Characteristics

Fig 1. Output Characteristic ($T_J = -55^\circ\text{C}$)

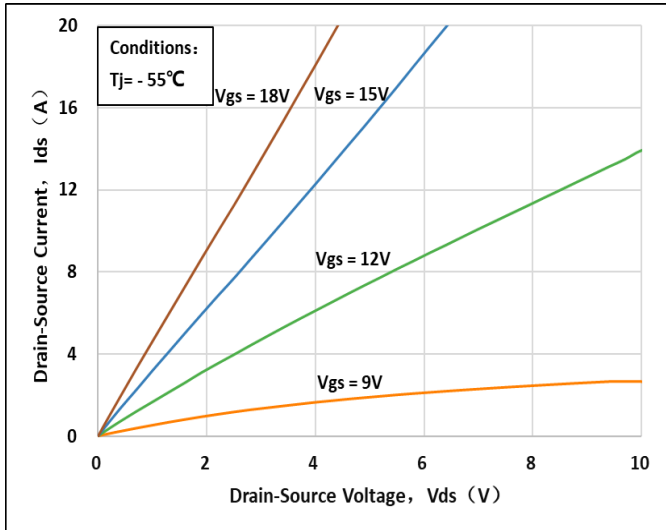

Fig 2. Output Characteristic ($T_J = 25^\circ\text{C}$)

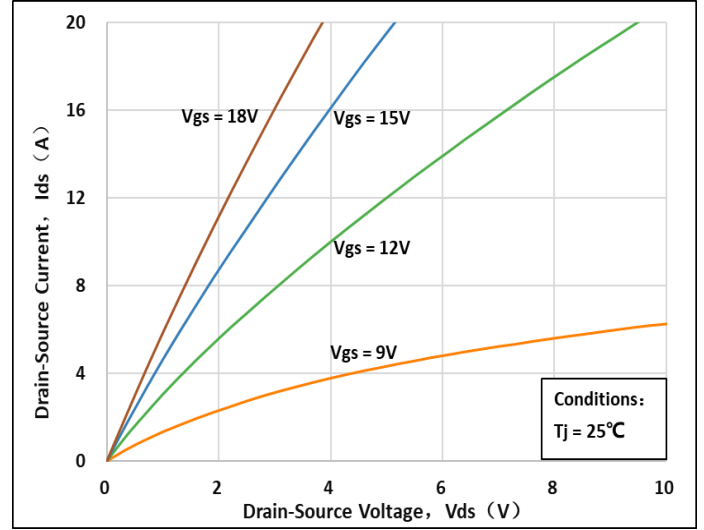

Fig 3. Output Characteristic ($T_J = 175^\circ\text{C}$)

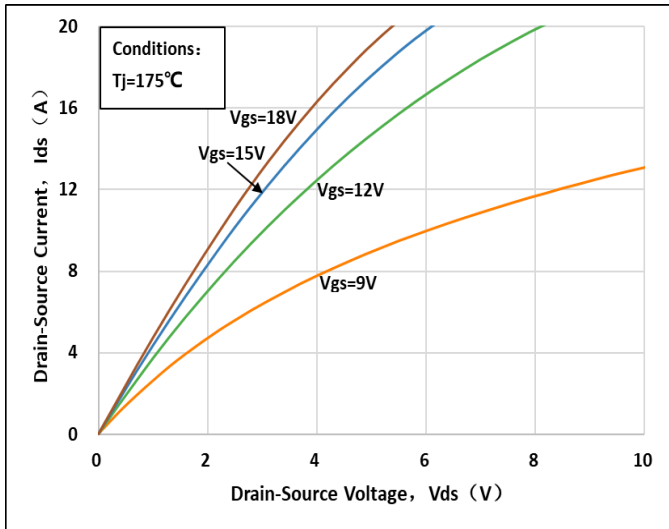

Fig 4: $R_{ds(on)}$ Vs I_{ds} Characteristic

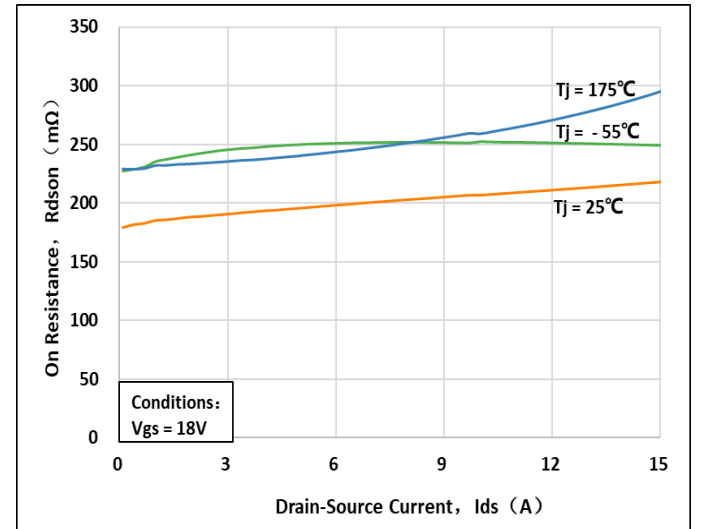

Fig 5: $R_{ds(on)}$ vs. Temperature

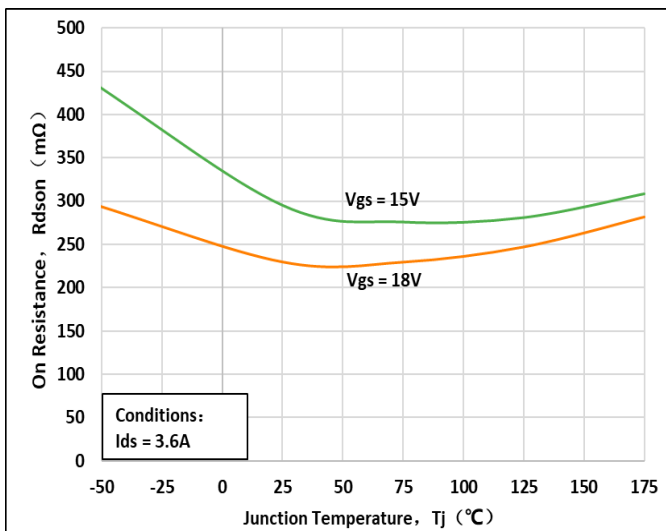

Fig 6: Transfer Characteristic

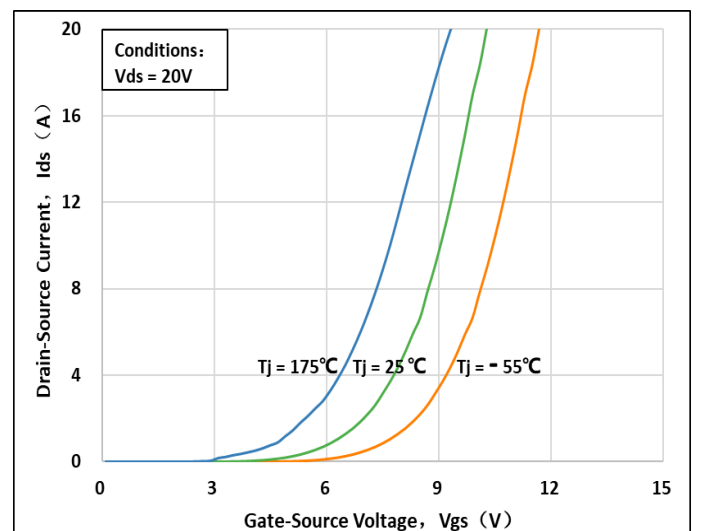

Fig 7: Body-diode Characteristic ($T_J = -55^\circ\text{C}$)

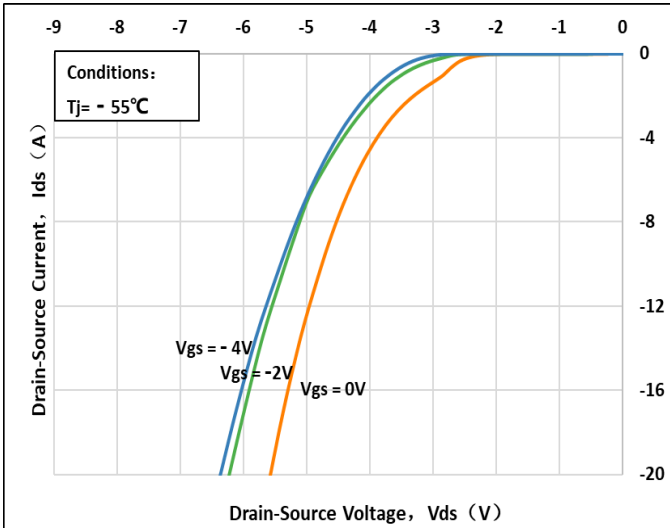

Fig 8: Body-diode Characteristic ($T_J = 25^\circ\text{C}$)

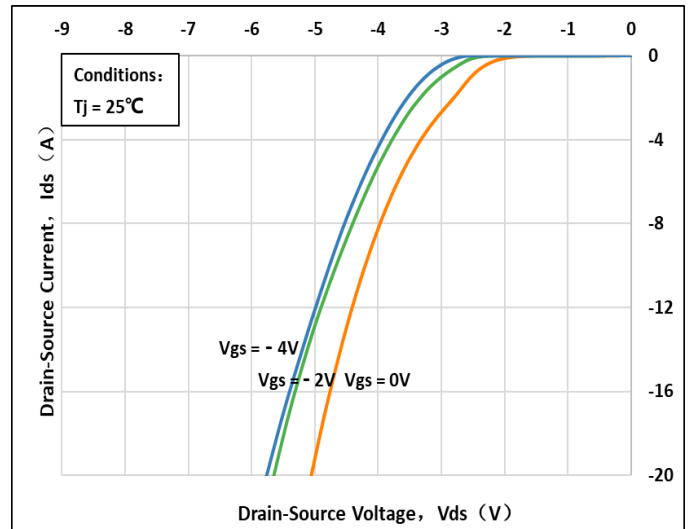

Fig 9: Body-diode Characteristic ($T_J = 175^\circ\text{C}$)

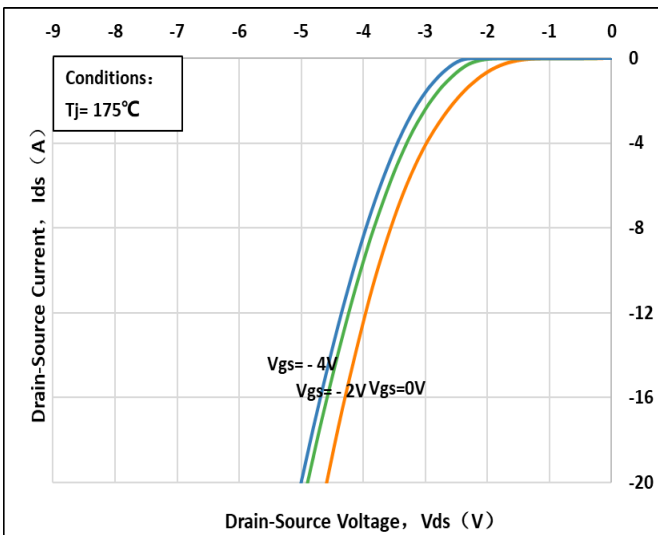

Fig 10: V_{TH} Vs T_J Temperature Characteristic

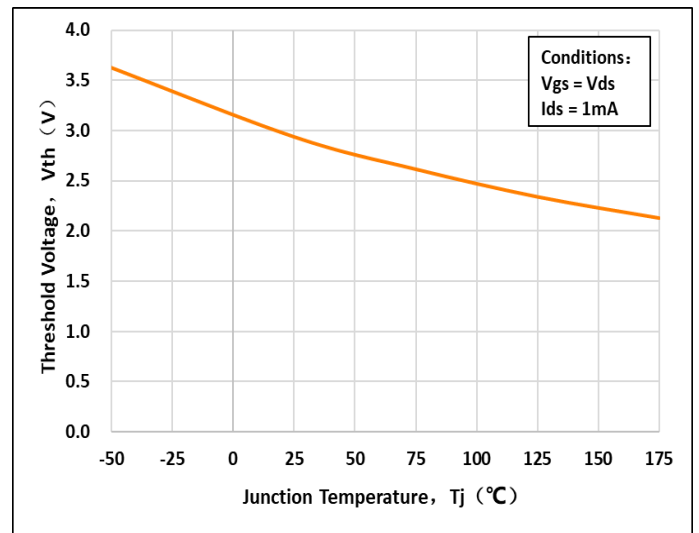

Fig 11: 3rd Quadrant Characteristic ($T_J = -55^\circ\text{C}$)

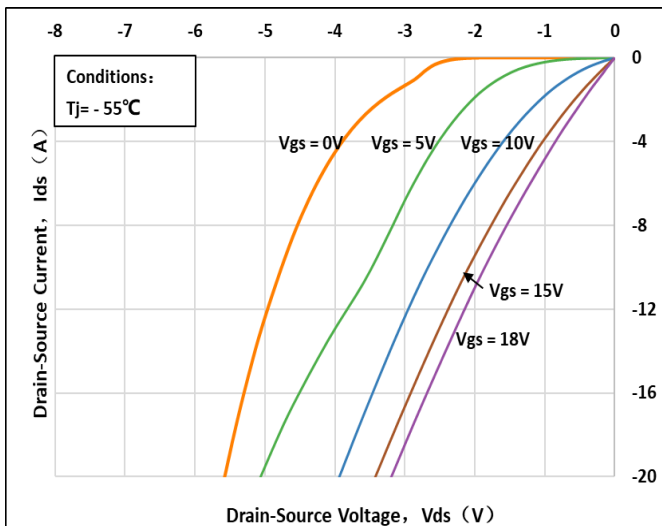

Fig 12: 3rd Quadrant Characteristic ($T_J = 25^\circ\text{C}$)

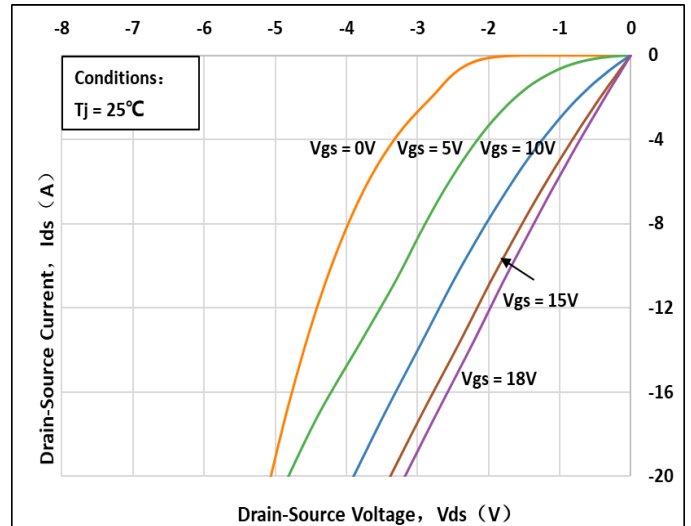

Fig 13: 3rd Quadrant Characteristic($T_j=175^\circ\text{C}$)

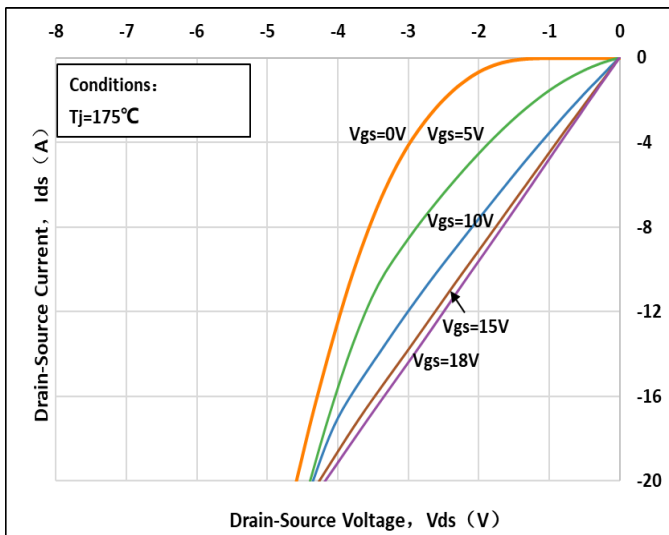

Fig 14: Gate Charge Characteristics

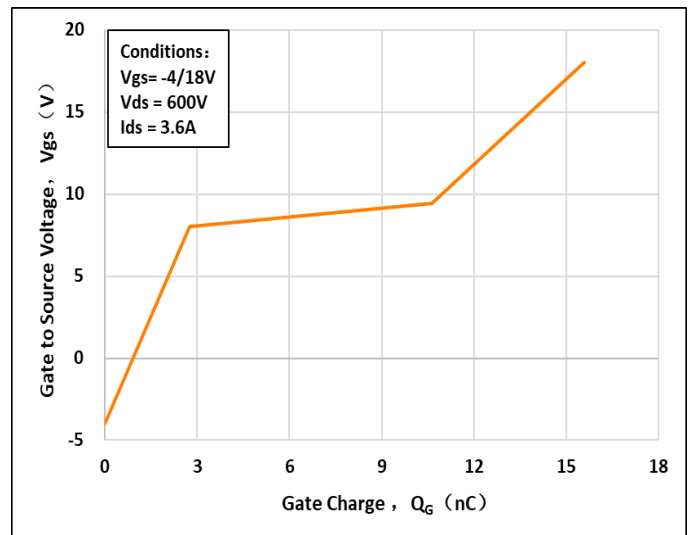

Fig 15: Drain Current vs. Case Temperature

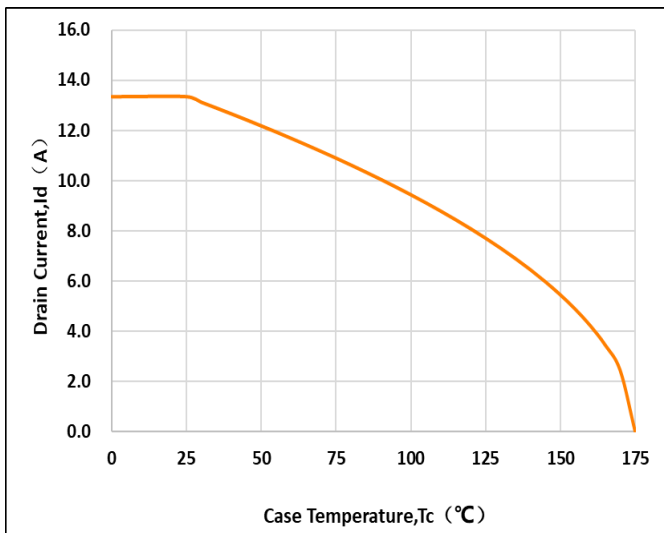

Fig 16: Safe Operating Area

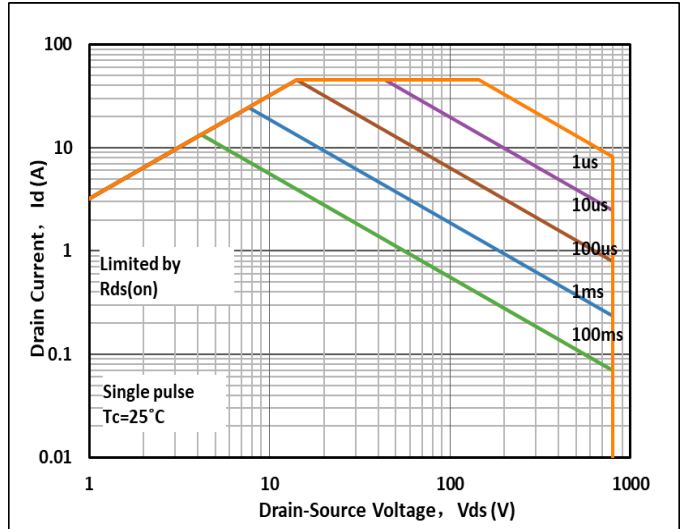

Fig 17: Capacitance Characteristics

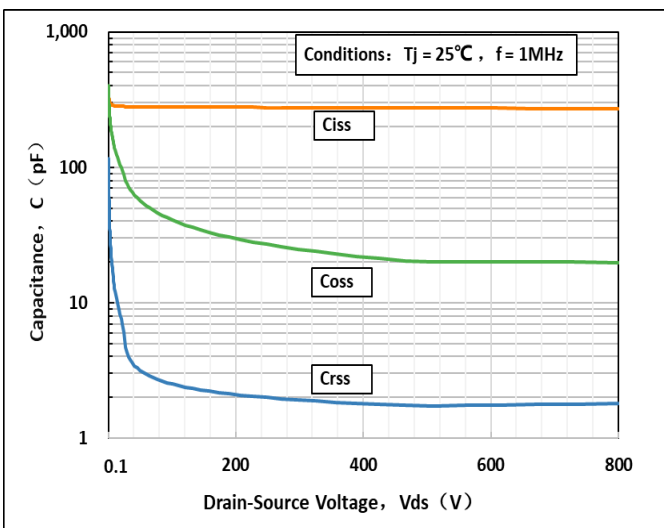
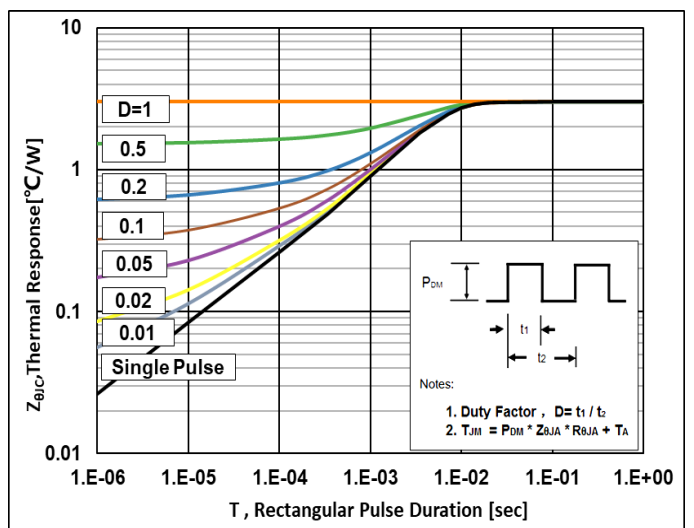
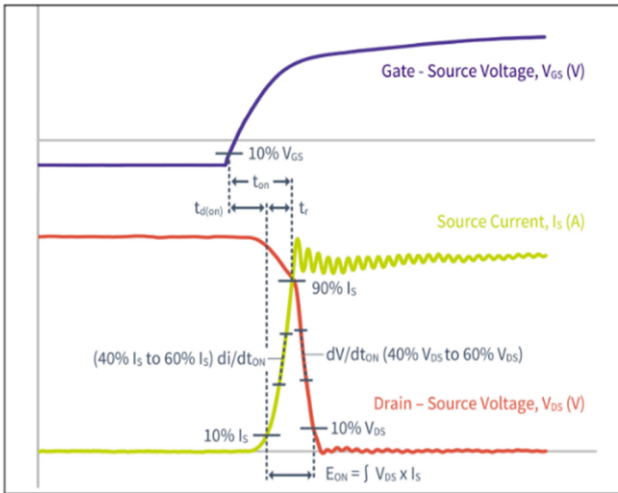

Fig 18: Transient Thermal Impedance



Test Circuit & Waveform

Figure A. Definition of switching times



Turn-on Transient Definitions

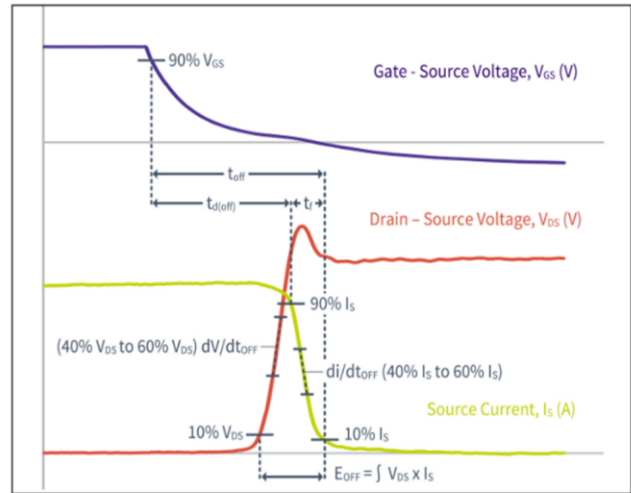

Turn-off Transient Definitions

Figure B. Dynamic test circuit

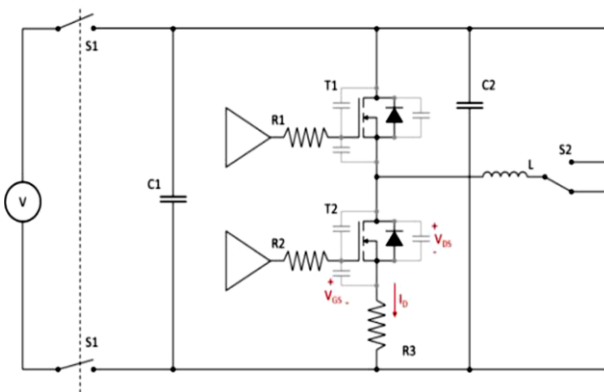
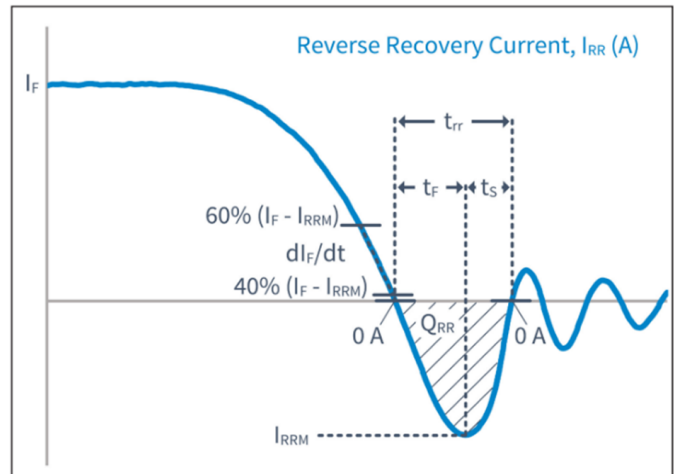
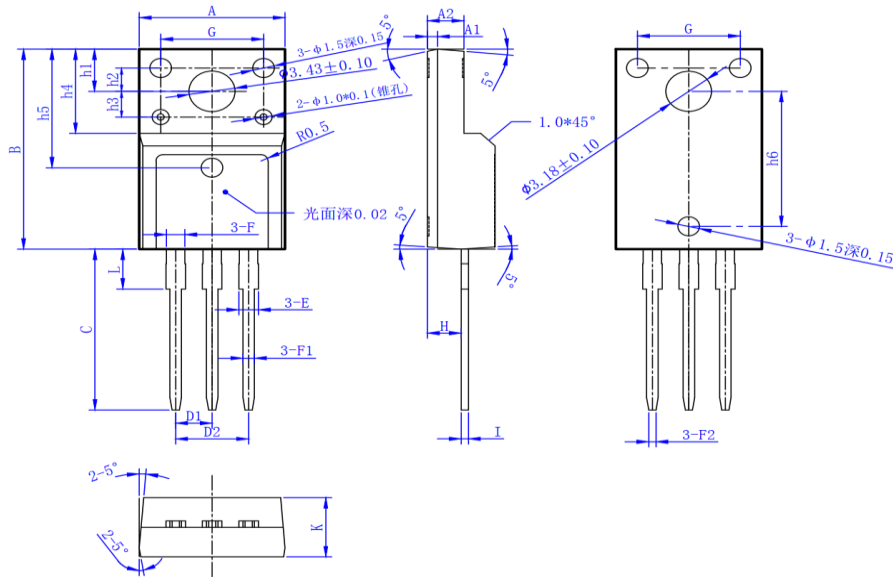

Figure C. Definition of body diodeswitching characteristics



Reverse Recovery Definitions

Package Outline:



SYMBOL	MM		
	MIN	NOM	MAX
*A	10.00	10.20	10.40
A1		0.70	
*A2	2.35	2.55	2.75
*B	15.80	15.90	16.00
*C	13.00	13.25	13.50
*D1		2.54BSC	
*D2		5.08BSC	
*E	1.27	1.32	1.40
F	1.25	1.28	1.30
*F1	0.75	0.80	0.85
F2	0.35	0.40	0.50
G	6.90	7.00	7.10
*H	2.66	2.76	2.86
h1	3.20	3.30	3.40
h2	1.70	1.80	1.90
h3	2.00	2.10	2.20
h4	6.70	6.79	6.90
h5	9.30	9.41	9.50
h6	10.44	10.54	10.64
*I	0.40	0.50	0.60
*K	4.60	4.70	4.80
L	2.90	3.00	3.10

带*为检验尺寸, C之尺寸参考原则必须满足有“尖脚”

Revision History

Revision	Date	Major changes
1.0		Release of temporary version

Disclaimer

Exceeding the maximum ratings of the device in performance may cause damage to the device, even the permanent failure, which may affect the dependability of the machine. It is suggested to be used under 80 percent of the maximum ratings of the device.

1. When installing the heatsink, please pay attention to the torsional moment and the smoothness of the heatsink.
2. This product has not been designed or tested for use in, and is not intended for use in, applications implanted into the human body nor in applications in which failure of the product could lead to death, personal injury or property damage, including but not limited to equipment used in the operation of nuclear facilities, life-support machines, cardiac defibrillators or similar emergency medical equipment, aircraft navigation or communication or control systems, or air traffic control systems.