

### Features

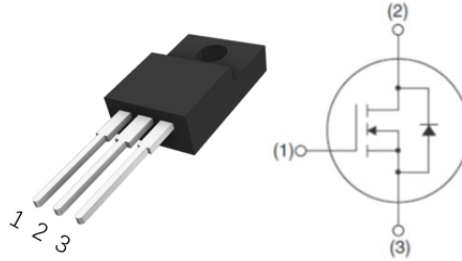
- High Blocking Voltage with Low On-Resistance
- High Speed Switching with Low Capacitances
- Avalanche Ruggednes

### Product Summary

$V_{DS}$	800V
$R_{DS(on)}_{typ}$	160mΩ
$I_D$	20A

### Applications

- Solar Inverters
- Switch Mode Power Supplies
- UPS
- Battery Chargers



### Package Marking and Ordering Information

Part #	Marking	Package
MX160080F	MX160080F	TO220F

### Absolute Maximum Ratings

Parameter	Symbol	Value	Unit
Drain-source voltage	$V_{DS}$	800	V
Continuous drain current $T_C = 25^\circ\text{C}$ $T_C = 125^\circ\text{C}$	$I_D$	20 11.5	A
Pulsed drain current ( $T_C = 25^\circ\text{C}$ , $t_p$ limited by $T_{jmax}$ )	$I_{D\ pulse}$	67	A
Gate-Source voltage	$V_{GS}$	-4/+18	V
Gate-Source voltage (Absolute maximum values)	$V_{GSmax}$	-8/+22	V
Power dissipation ( $T_C = 25^\circ\text{C}$ )	$P_{tot}$	65	W
Operating junction and storage temperature	$T_j, T_{stg}$	-55...+175	$^\circ\text{C}$

- Example of acceptable  $V_{GS}$  waveform



### Thermal Resistance

Parameter	Symbol	Value	Unit
Thermal resistance, junction – case. Max	$R_{thJC}$	2.3	°C/W

### Electrical Characteristic (at $T_j = 25\text{ }^\circ\text{C}$ , unless otherwise specified)

Parameter	Symbol	Value			Unit	Test Condition
		min.	typ.	max.		

#### Static Characteristic

Drain-source breakdown voltage	$V_{DSS}$	800	-	-	V	$V_{GS}=0V, I_D=100\mu A$
Gate threshold voltage	$V_{GS(th)}$	2	2.8	4	V	$V_{DS}=V_{GS}, I_D=1mA$
Zero gate voltage drain current	$I_{DSS}$	-	1	10	$\mu A$	$V_{DS}=800V, V_{GS}=0V$ $T_C=25^\circ C$ $T_C=175^\circ C$
Gate-source leakage current	$I_{GSS}$	-	-	100	nA	$V_{GS}=18V, V_{DS}=0V$
Drain-source on-state resistance	$R_{DS(on)}$	-	160	205	mΩ	$V_{GS}=18V, I_D=7A,$ $T_J=25^\circ C$ $T_J=175^\circ C$

#### Dynamic Characteristic

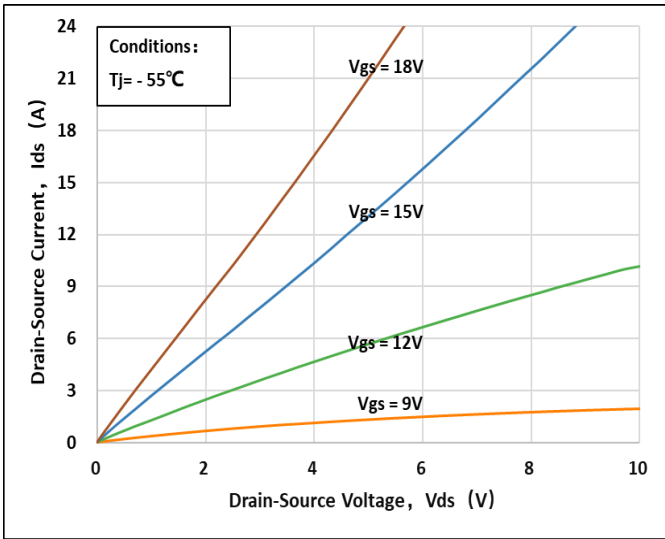
Input Capacitance	$C_{iss}$	-	484	-	pF	$V_{DS} = 600V$ $V_{GS} = 0V$ $T_J = 25^\circ C$ $V_{AC} = 25mV$ $f = 1MHz$	
Output Capacitance	$C_{oss}$	-	46.6	-			
Reverse Transfer Capacitance	$C_{rss}$	-	5.6	-			
Gate Total Charge	$Q_G$	-	18.2	-	nC	$V_{DS} = 600V$ $V_{GS} = -4/18V$ $I_D = 7A$	
Gate-Source charge	$Q_{gs}$	-	6.6	-			
Gate-Drain charge	$Q_{gd}$	-	3.6	-			
Turn-On Switching Energy	$E_{ON}$	-	62.5	-	$\mu J$	$V_{DD} = 600V$ $V_{GS} = -4/+18V$ $I_D = 7A$ $R_G = 5\Omega$	
Turn-Off Switching Energy	$E_{OFF}$	-	9.53	-			
Turn-on delay time	$t_{d(on)}$	-	38.7	-	ns		
Rise time	$t_r$	-	13.5	-			
Turn-off delay time	$t_{d(off)}$	-	49.2	-			
Fall time	$t_f$	-	14.5	-			
Gate resistance	$R_G$	-	3.7	-	$\Omega$		$V_{AC} = 25mV, f=1MHz$

### Body Diode Characteristic

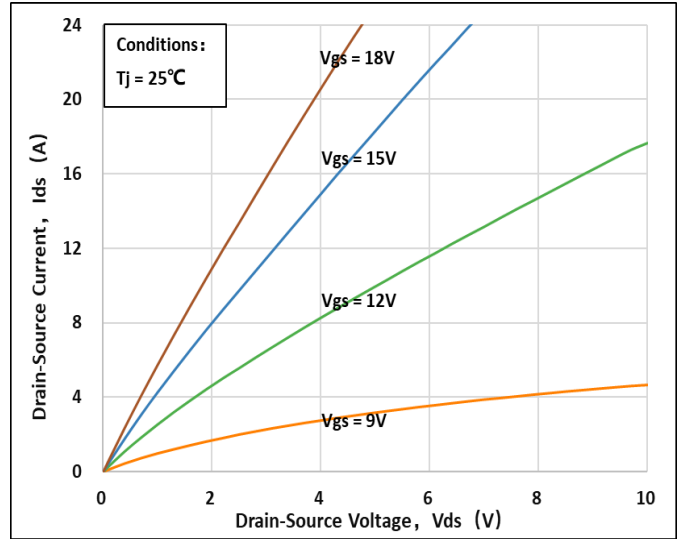
Parameter	Symbol	Value			Unit	Test Condition
		min.	typ.	max.		
Body Diode Forward Voltage	$V_{SD}$		3		V	$V_{GS} = 0V, I_{SD} = 3.5A,$ $T_J = 25^\circ C$
			2.7			$V_{GS} = 0V, I_{SD} = 3.5A,$ $T_J = 175^\circ C$
Body Diode Reverse Recovery Time	$t_{rr}$	-	62	-	ns	$V_R = 600V, V_{GS} = 0V$ $I_D = 7A$
Body Diode Reverse Recovery Charge	$Q_{rr}$	-	31.8	-	nC	$di/dt = 800A/\mu S$ $T_J = 175^\circ C$

**Typical Performance Characteristics**

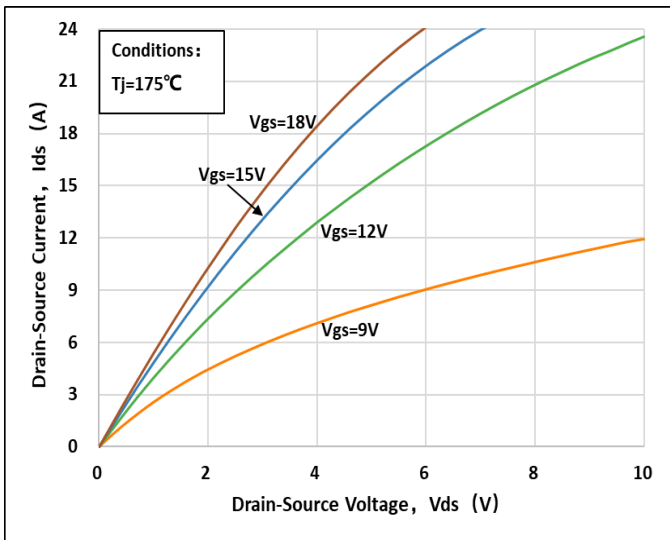
**Fig 1. Output Characteristic ( $T_J = -55^\circ\text{C}$ )**



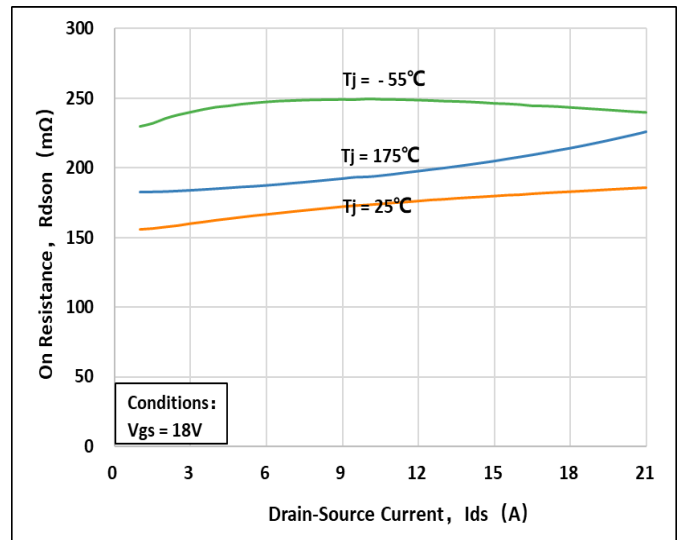
**Fig 2. Output Characteristic ( $T_J = 25^\circ\text{C}$ )**



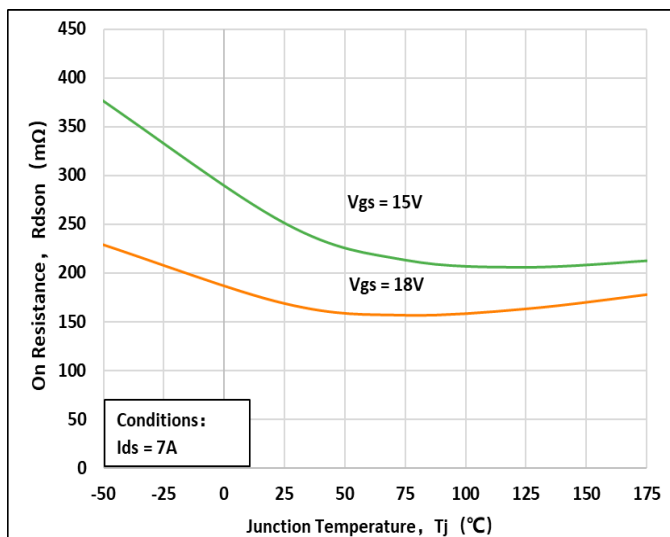
**Fig 3. Output Characteristic ( $T_J = 175^\circ\text{C}$ )**



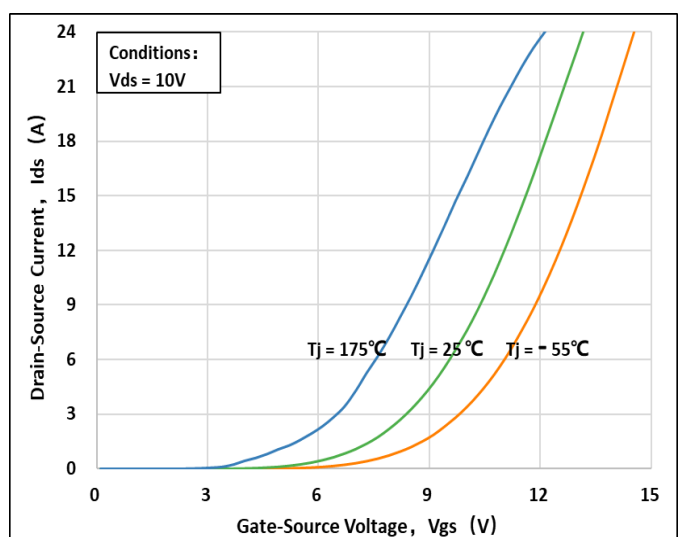
**Fig 4:  $R_{ds(on)}$  Vs  $I_{ds}$  Characteristic**



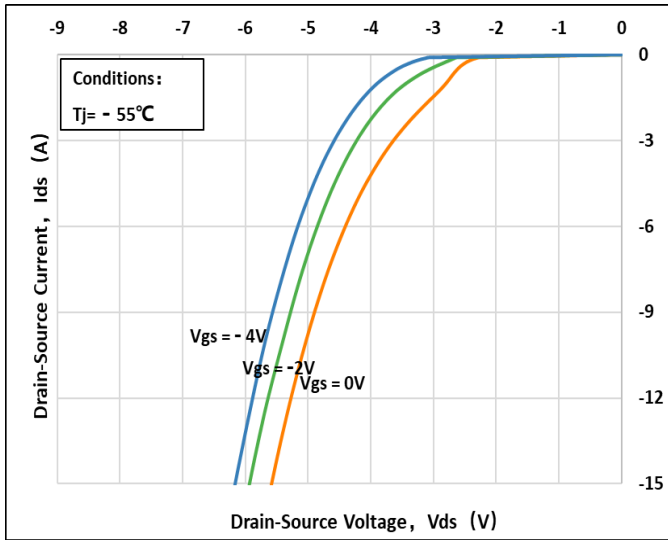
**Fig 5:  $R_{ds(on)}$  vs. Temperature**



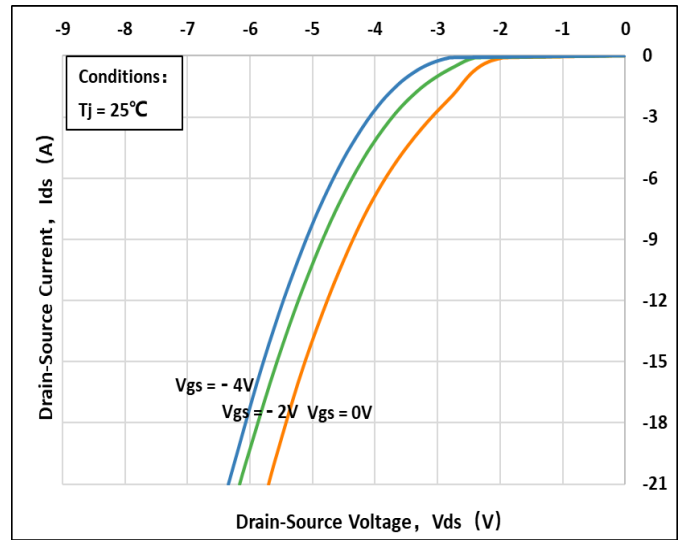
**Fig 6: Transfer Characteristic**



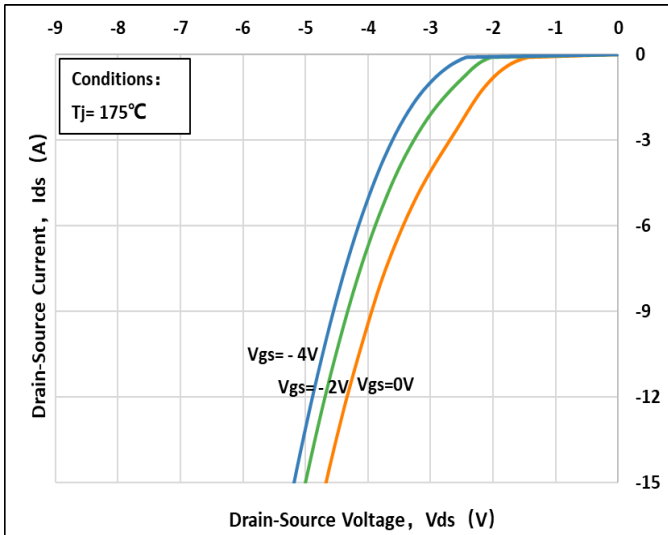
**Fig 7: Body-diode Characteristic ( $T_J=-55^{\circ}\text{C}$ )**



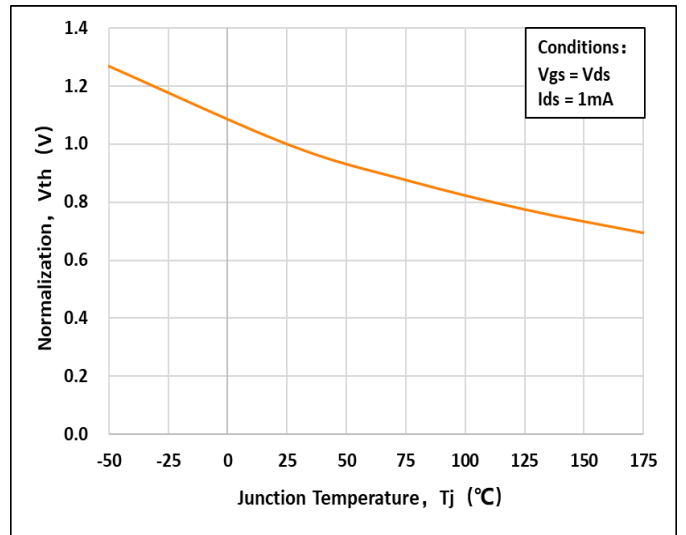
**Fig 8: Body-diode Characteristic ( $T_J=25^{\circ}\text{C}$ )**



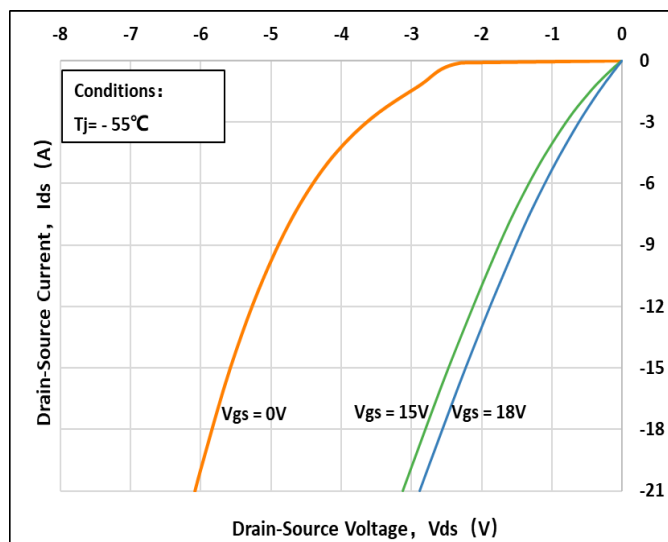
**Fig 9: Body-diode Characteristic ( $T_J=175^{\circ}\text{C}$ )**



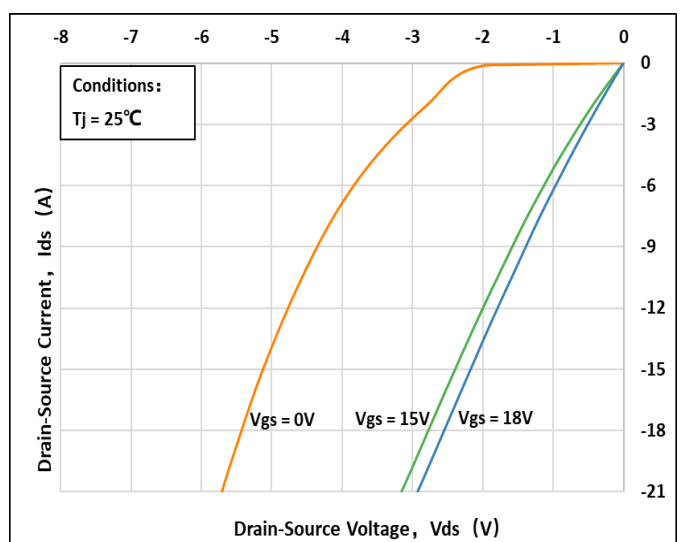
**Fig 10:  $V_{TH}$  Vs  $T_J$  Temperature Characteristic**



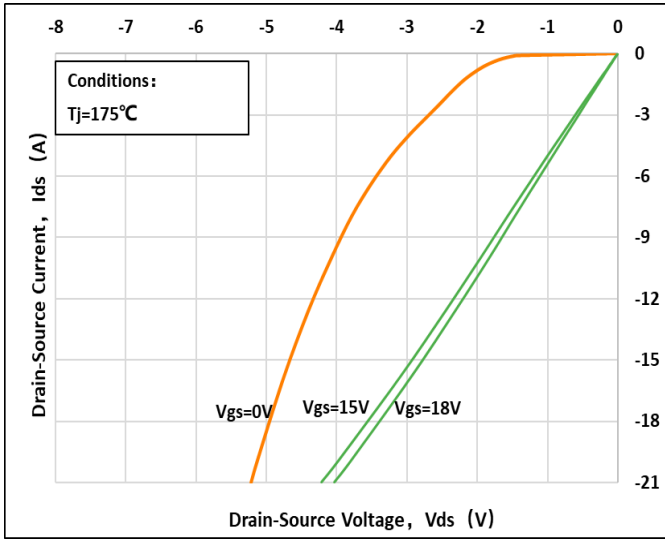
**Fig 11: 3rd Quadrant Characteristic( $T_J=-55^{\circ}\text{C}$ )**



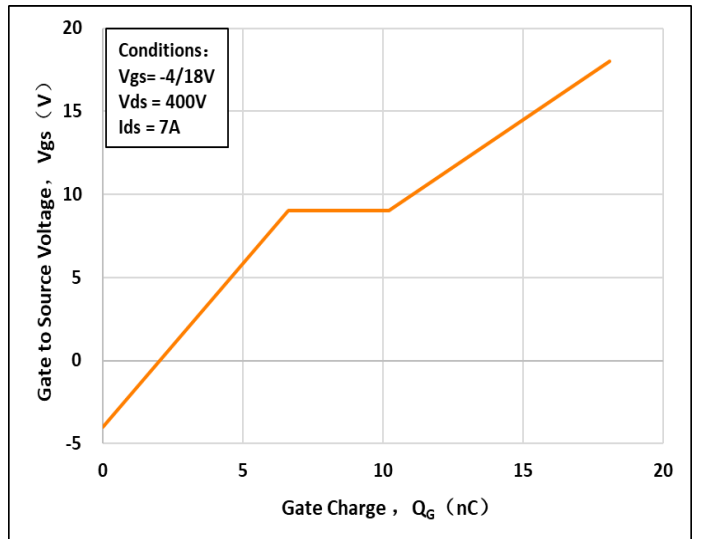
**Fig 12: 3rd Quadrant Characteristic( $T_J=25^{\circ}\text{C}$ )**



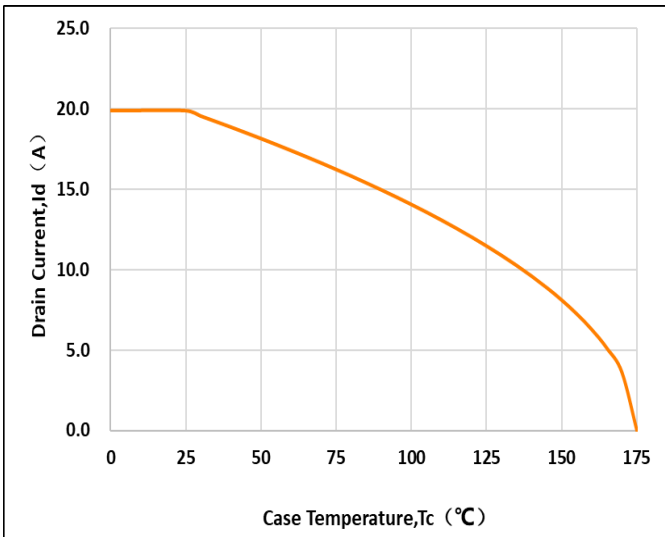
**Fig 13: 3rd Quadrant Characteristic(T<sub>J</sub>=175°C)**



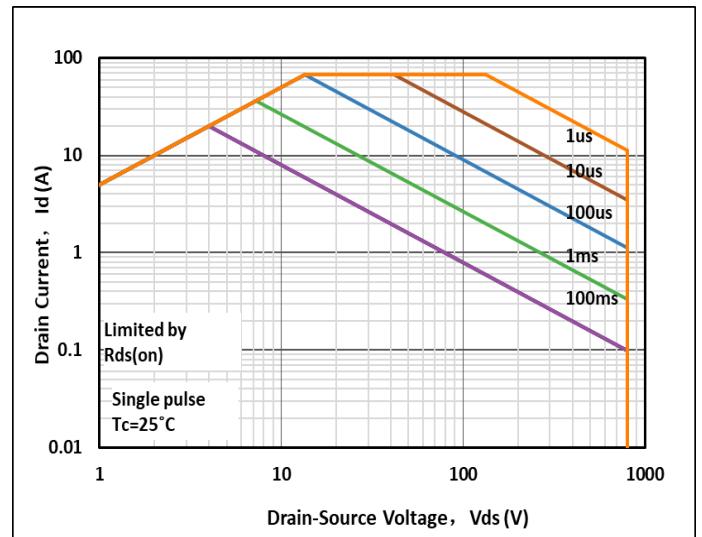
**Fig 14: Gate Charge Characteristics**



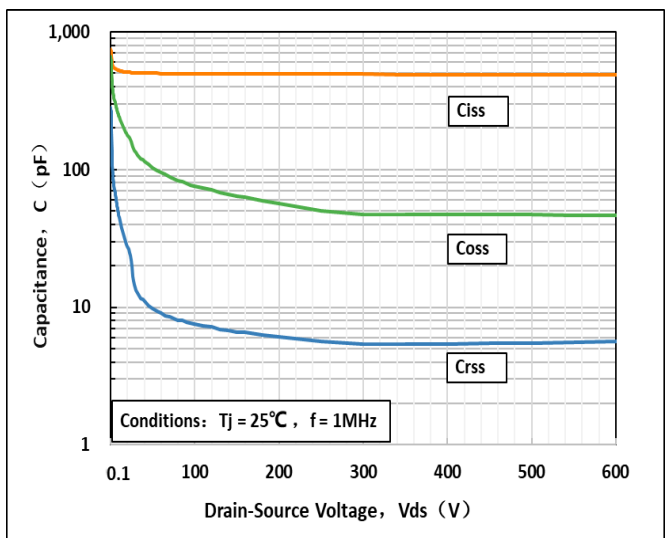
**Fig 15: Continuous Drain Current vs. Case Temperature**



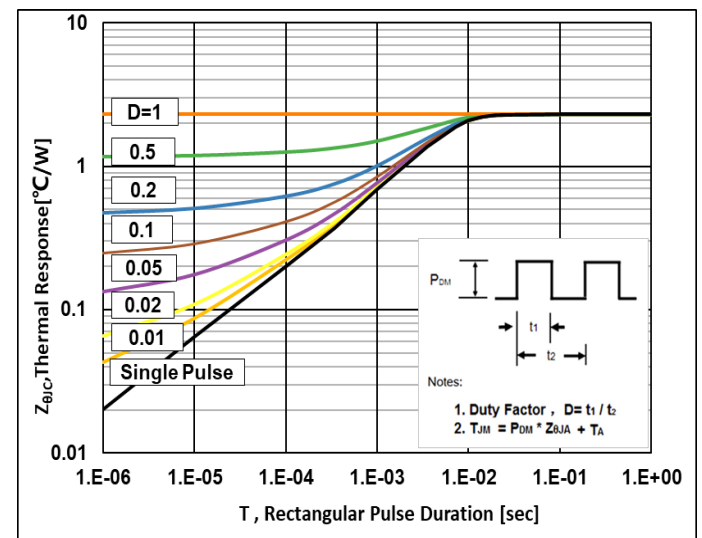
**Fig 16: Safe Operating Area**



**Fig 17: Capacitance Characteristics**

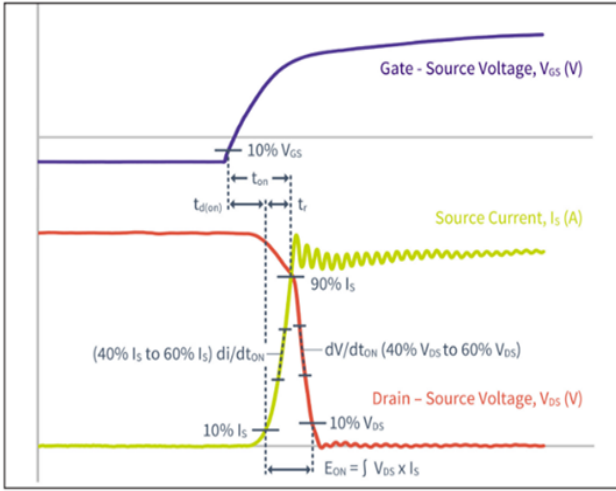


**Fig 18: Transient Thermal Impedance**

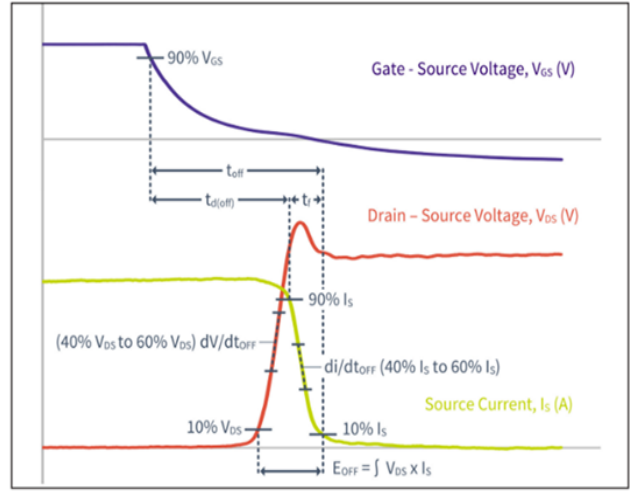


**Test Circuit & Waveform**

**Figure A. Definition of switching times**

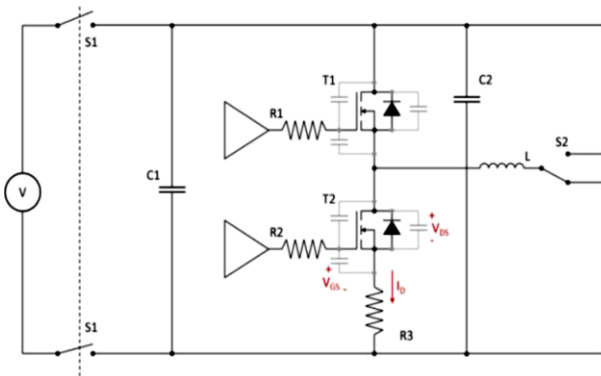


Turn-on Transient Definitions

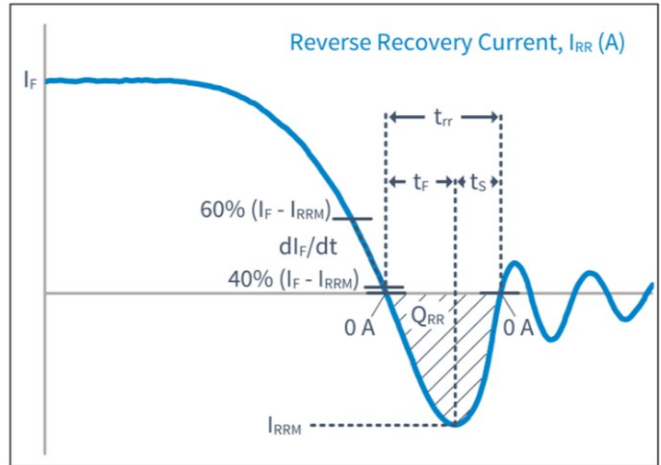


Turn-off Transient Definitions

**Figure B. Dynamic test circuit**

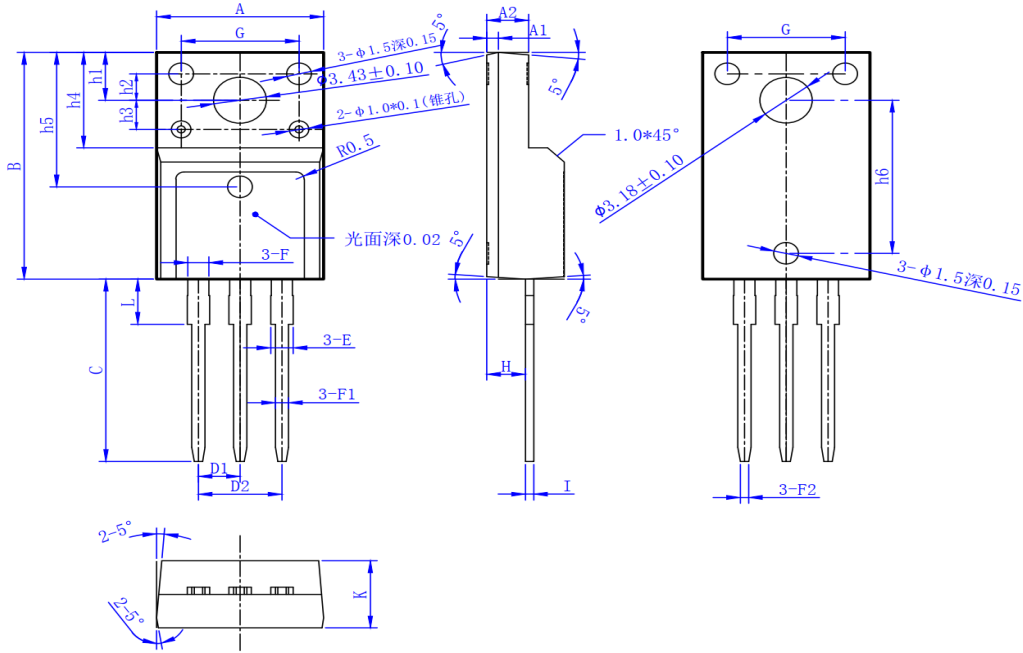


**Figure C. Definition of body diodeswitching characteristics**



Reverse Recovery Definitions

**Package Outline:**



SYMBOL	MM		
	MIN	NOM	MAX
*A	10.00	10.20	10.40
A1		0.70	
*A2	2.35	2.55	2.75
*B	15.80	15.90	16.00
*C	13.00	13.25	13.50
*D1		2.54BSC	
*D2		5.08BSC	
*E	1.27	1.32	1.40
F	1.25	1.28	1.30
*F1	0.75	0.80	0.85
F2	0.35	0.40	0.50
G	6.90	7.00	7.10
*H	2.66	2.76	2.86
h1	3.20	3.30	3.40
h2	1.70	1.80	1.90
h3	2.00	2.10	2.20
h4	6.70	6.79	6.90
h5	9.30	9.41	9.50
h6	10.44	10.54	10.64
*I	0.40	0.50	0.60
*K	4.60	4.70	4.80
L	2.90	3.00	3.10
带*为检验尺寸, C之尺寸参考原则必须满足有“尖脚”			

---

**Revision History**

Revision	Date	Major changes
1.0		Release of temporary version

**Disclaimer**

Exceeding the maximum ratings of the device in performance may cause damage to the device, even the permanent failure, which may affect the dependability of the machine. It is suggested to be used under 80 percent of the maximum ratings of the device.

1. When installing the heatsink, please pay attention to the torsional moment and the smoothness of the heatsink.
2. This product has not been designed or tested for use in, and is not intended for use in, applications implanted into the human body nor in applications in which failure of the product could lead to death, personal injury or property damage, including but not limited to equipment used in the operation of nuclear facilities, life-support machines, cardiac defibrillators or similar emergency medical equipment, aircraft navigation or communication or control systems, or air traffic control systems..