

## GENERAL DESCRIPTION

The MX3501T23 of push pull output comparator feature a fast 4.5ns propagation delay and operation from 2.7V to 5.5V. Beyond the rails input common-mode range makes it an ideal choice for low voltage applications. The rail to rail output directly drives either CMOS or TTL logic.

Micro-size package provide option for portable and space restricted applications. The single is available in SOT23-6.

## FEATURES

- ◆ High Speed: 4.5ns
- ◆ Rail to Rail I/O
- ◆ Supply Voltage: 2.7V to 5.5V
- ◆ Push Pull CMOS Output Stage
- ◆ Shutdown
- ◆ Low Supply Current: 3.2mA
- ◆ 6-Pin SOT23 Package

## APPLICATIONS

Test equipment

Wireless base stations  
 Threshold detectors  
 Zero crossing detectors  
 Window comparators  
 Test equipment

## GENERAL INFORMATION

### Ordering information

Part Number	Description	MPQ
MX3501T23	SOT23-6L	3K

### Package dissipation rating

Package	RθJA (°C/W)
SOT23-6L	200

### Absolute maximum ratings

Parameter	Value
Supply voltage	-0.7to 6V
IN+, IN- signal pin voltage	(V <sub>-</sub> )-0.3 to (V <sub>+</sub> )+0.3
IN+, IN- signal pin current	10mA max
OUT pin short circuit	70mA
Junction temperature	150°C
Storage temperature, Tstg	-55 to 150°C
Leading temperature (soldering, 10secs)	260°C
ESD Susceptibility HBM	±2000V

Stresses beyond those listed in Absolute Maximum Ratings may cause permanent damage to the device. Exposure to absolute maximum rating conditions for extended periods may affect reliability. Functional operation of the device at any conditions beyond those indicated in the Recommended Operating Conditions section is not implied.

### Recommended operating condition

Symbol	Parameter	Range
Supply	Supply voltage	2.7-5.5V
Junction temperature		-40~125°C
PD	Power dissipation	0.50W

## TYPICAL APPLICATION

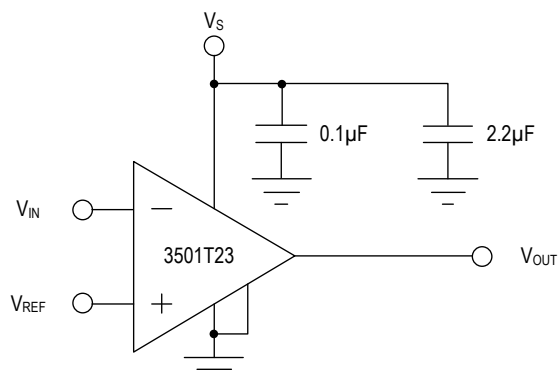

Basic connections for the MX3501T23

## TERMINAL ASSIGNMENTS

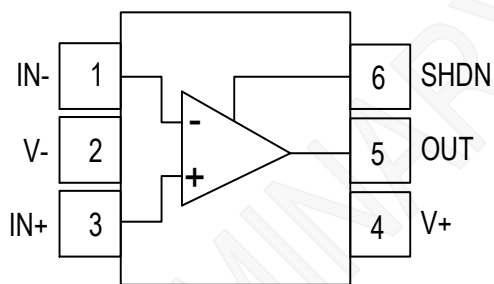

Pin information

PIN NO.	PIN name	Description
1	IN-	Negative (inverting) input
2	V-	Negative (lowest) power supply
3	IN+	Positive (noninverting) input
4	V+	Positive (highest) power supply
5	OUT	Output
6	SHDN	Shutdown (the device is idle when this pin is not in use)

## BLOCK DIAGRAM

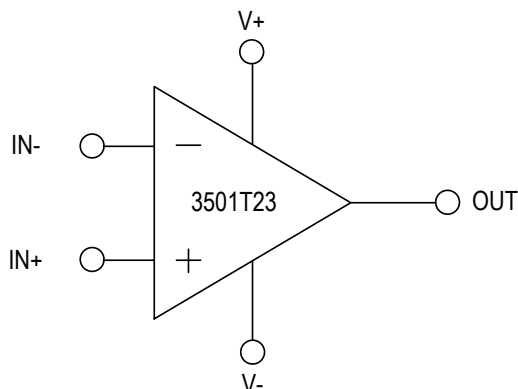

## Electrical characteristics

( $T_A=25^{\circ}\text{C}$ ,  $V_{DD}=2.7\text{-}5.5\text{V}$ , unless otherwise noted)

Symbol	Parameter	Test condition	Min	Typ.	Max	Unit
<b>OFFSET VOLTAGE</b>						
Input offset voltage	$V_{OS}$	$V_{CM}=0\text{V}$ , $I_O=0\text{mA}$		$\pm 1$	$\pm 6.5$	mV
Input offset voltage vs temperature	$dV_{OS}/dT$	$T_A=-40^{\circ}\text{C}$ to $+125^{\circ}\text{C}$		$\pm 5$		$\mu\text{V}/^{\circ}\text{C}$
Input offset voltage vs power supply	PSRR	$V_S=2.7\text{V}$ to $5.5\text{V}$		100	400	$\mu\text{V}/\text{V}$
Input hysteresis				6		mV
<b>INPUT BASIC CURENT</b>						
Input basic current	$I_B$	$V_{CM}=V_{CC}/2$		$\pm 2$	$\pm 10$	pA
Input offset current	$I_{OS}$	$V_{CM}=V_{CC}/2$		$\pm 2$	$\pm 10$	pA
<b>INPUT VOLTAGE RANGE</b>						
Common mode voltage range			$(V_-)-0.2$		$(V_+)-0.2$	V
Common mode rejection ratio	CMRR	$V_{CM}=-0.2\text{V}$ to $(V_+)+0.2\text{V}$		57	70	dB
		$T_A=-40^{\circ}\text{C}$ to $+125^{\circ}\text{C}$		55		dB
<b>INPUT IMPEDENCE</b>						
Common mode				$10^{13}/2$		$\Omega/\text{pF}$
differential				$10^{13}/4$		$\Omega/\text{pF}$
<b>OUTPUT</b>						
Voltage output swing from rail	$V_{OH}$ , $V_{OL}$	$I_{OUT}=\pm 1\text{mA}$		30	50	mV
<b>SHUTDOWN</b>						
Shutdown turn-off time	$T_{OFF}$			30		ns
Shutdown turn-on time	$T_{ON}$			100		ns
SHDN low threshold	$V_L$	Comparator disabled			$(V_+)-1.7$	V
SHDN high threshold	$V_H$	Comparator disabled	$(V_+)-0.9$			V
Input bias current of shutdown pin				2		pA
Quiescent current in shutdown	$I_{QSD}$			2		$\mu\text{A}$
<b>POWER SUPPLY</b>						
Specified voltage	$V_S$		2.7		5.5	V
Operating voltage range		Higher end		2.2		V
		Lower end		5.5		V
Quiescent current	$I_Q$	$V_S=5\text{V}$ , $V_O=\text{High}$		3.2	5	mA
<b>SWITCHING CHARACTERISTICS</b>						
Propagation delay time	TPD	$T_A=25^{\circ}\text{C}$		4.5	6.5	ns

## 4.5ns , Rail to Rail , High Speed Comparator

	$\Delta V_{IN}=100\text{mV}$ , overdrive=20mV	$T_A=-40^\circ\text{C}$ to $+125^\circ\text{C}$			7	ns
	TPD	$T_A=25^\circ\text{C}$		7.5	10	ns
	$\Delta V_{IN}=100\text{mV}$ , overdrive=5mV	$T_A=-40^\circ\text{C}$ to $+125^\circ\text{C}$			12	ns
Propagation delay skew	$\Delta T_{SKEW}$	$\Delta V_{IN}=100\text{mV}$ , overdrive=20mV		0.5		ns
Maximum toggle frequency	$F_{max}$	Overdrive=50mV, $V_S=5\text{V}$		80		MHz
Rise time	$T_R$			1.5		ns
Fall time	$T_F$			1.5		ns

PRELIMINARY

**Characteristic plots**

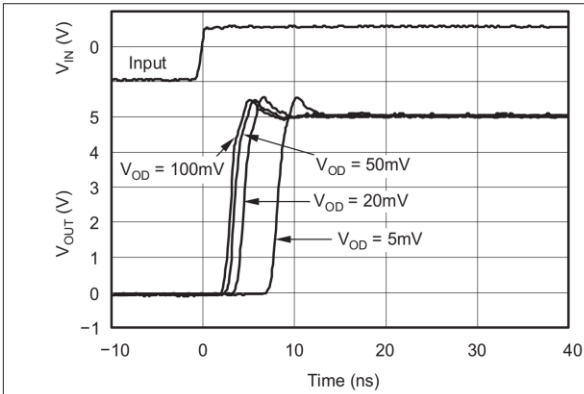

**Figure 1. Output Response for Various Overdrive Voltages (Rising)**

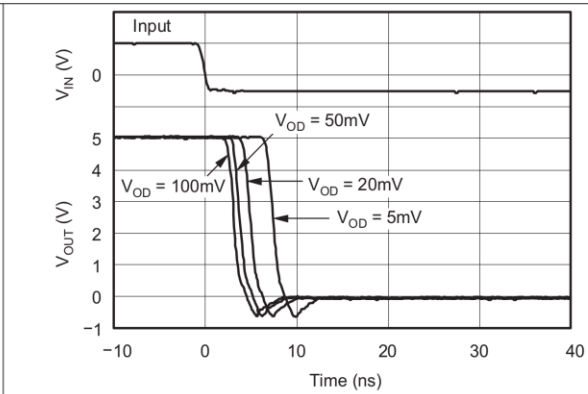

**Figure 2. Output Response for Various Overdrive Voltage (Falling)**

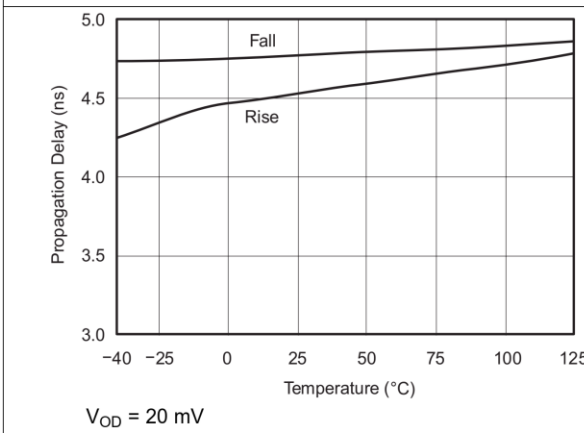

**Figure 3. Propagation Delay vs Temperature**

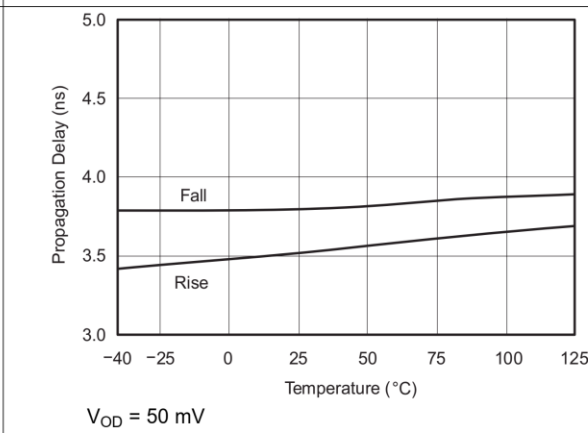

**Figure 4. Propagation Delay vs Temperature**

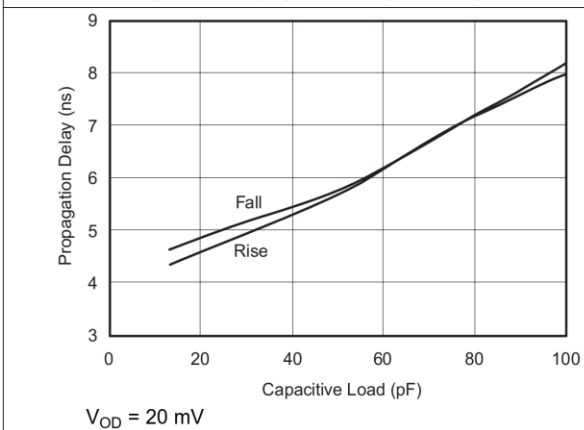

**Figure 5. Propagation Delay vs Capacitive Load**

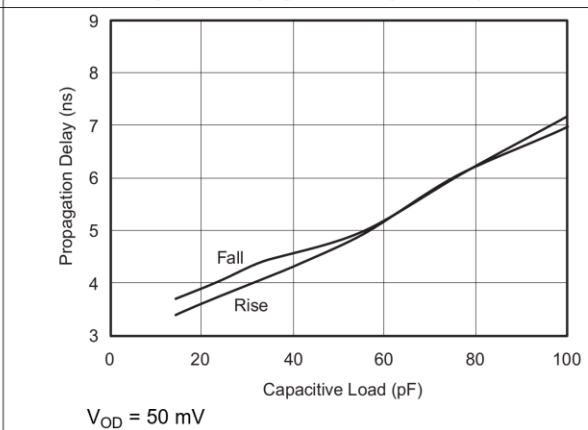

**Figure 6. Propagation Delay vs Capacitive Load**

4.5ns , Rail to Rail , High Speed Comparator

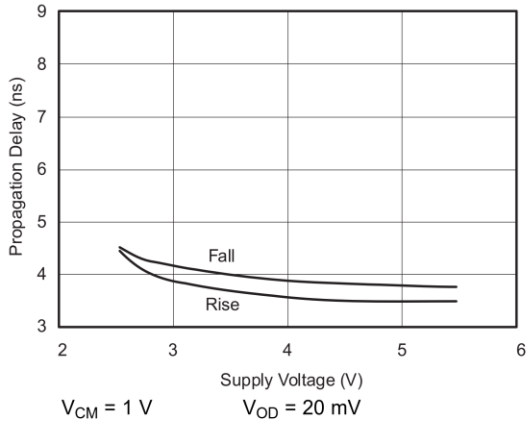

Figure 7. Propagation Delay vs Supply Voltage

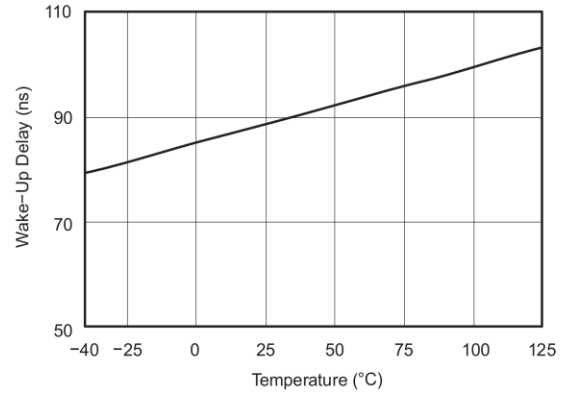

Figure 8. Wake-Up Delay vs Temperature

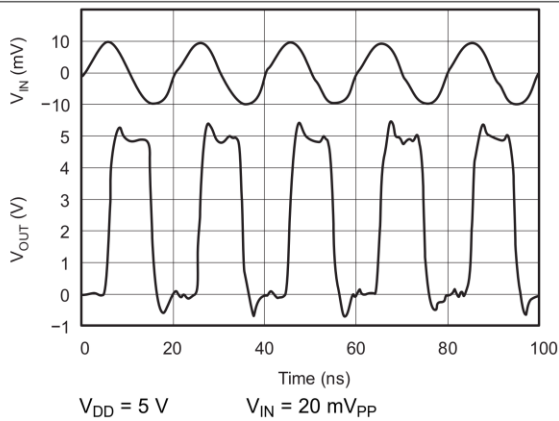

Figure 9. Response to 50-MHz Sine Wave

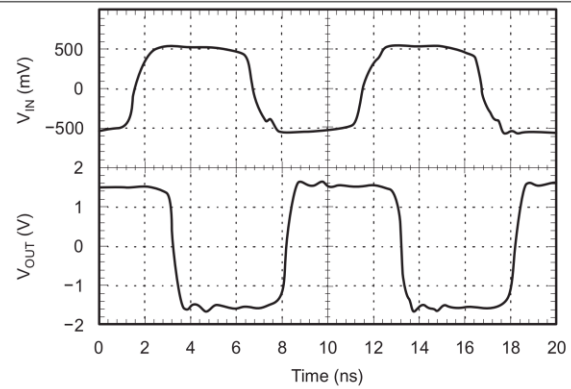

Figure 10. Response to 100-MHz Sine Wave ( $\pm 2.5\text{ V}$  Dual Supply into 50-Ω Oscilloscope Input)

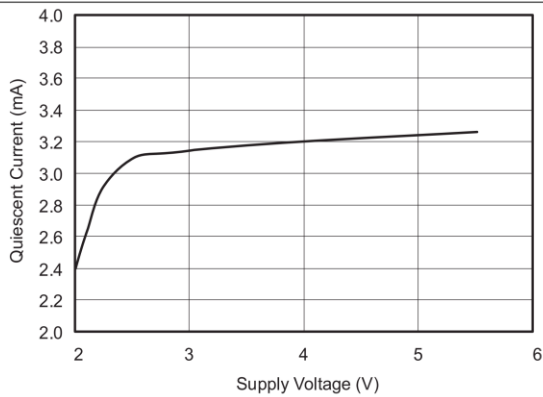

Figure 11. Quiescent Current vs Supply Voltage

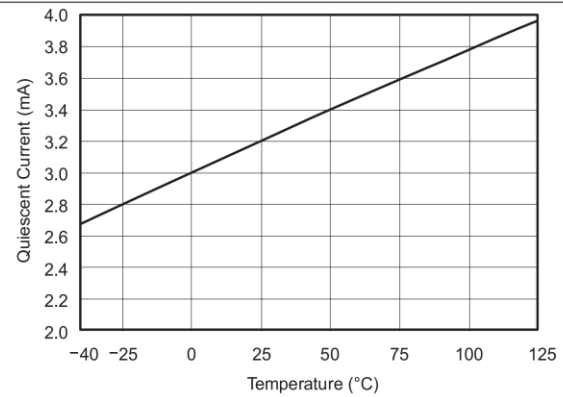

Figure 12. Quiescent Current vs Temperature

## Operation description

The MX3501T23 device both feature high speed and include 6mV of internal hysteresis for improved noise immunity with an input common mode range that extends 0.2V beyond the power supply rails.

## Operating Voltage

The MX3501T23 comparator is specified for use on a single supply from 2.7V to 5.5V (or a dual supply from  $\pm 1.35V$  to  $\pm 2.75V$ ) over a temperature range of  $-40^{\circ}C$  to  $+125^{\circ}C$ . This device continue to function below this range, but performance is not specified.

## Input Over voltage Protection

Device inputs are protected by electrostatic discharge diode that conduct if the input voltages exceed the power supplies by more than approximately 300mV. Momentary voltages greater than 300mV beyond the power supply can be tolerated if the input current is limited to 10mA. This limiting is easily accomplished with a small input resistor in series with the comparator, as shown in the below figure.

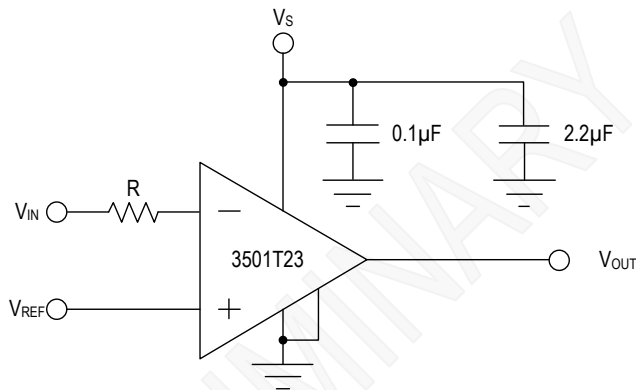

Input current protection for voltage exceeding the supply voltage

## Shutdown

A shutdown pin allows the device to go into idle when it is not in use. When the shutdown pin is high, the device draws approximately 2uA, and the output goes to high impedance. When the shutdown pin is low, the MX3501T23 is active. When the MX3501T23 shutdown feature is not used, connect the shutdown pin to the most negative supply, as shown in the below figure. Exiting shutdown mode requires approximately 100ns.

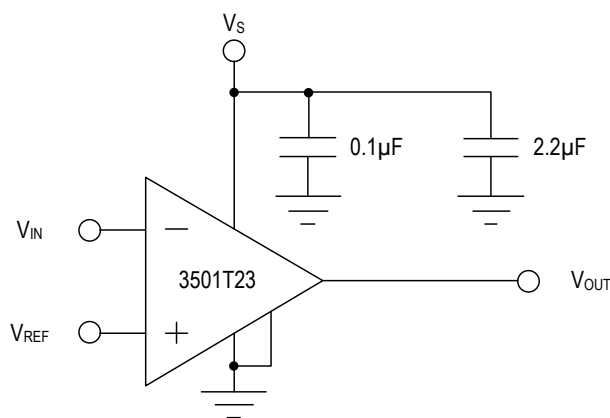

Basic connection for the MX3501T23

## Application Information

## 4.5ns , Rail to Rail , High Speed Comparator

The MX3501T23 has a robust performance when used with a good layout. However, comparator inputs have little noise immunity within the range of a specified offset voltage. For slow moving or noisy input signals, the comparator output can cause an undesirable switch state as input signals move through the switching threshold. In such applications, the 6mV of internal hysteresis of the MX3501T23 might not be sufficient. For greater noise immunity, external hysteresis can be added by connecting a small amount of feedback to the positive input. The next figure shows a typical topology used to introduce 25mV of additional hysteresis, for a total of 31mV hysteresis when operating from a single 5V supply. Use the following equation to calculate the approximate total hysteresis.

$$V_{HYST} = \frac{(V+) \times R_1}{R_1 + R_2} + 6mV$$

The total hysteresis sets the value of the transition voltage required to switch the comparator output, by enlarging the threshold region, thereby reducing sensitivity to noise.

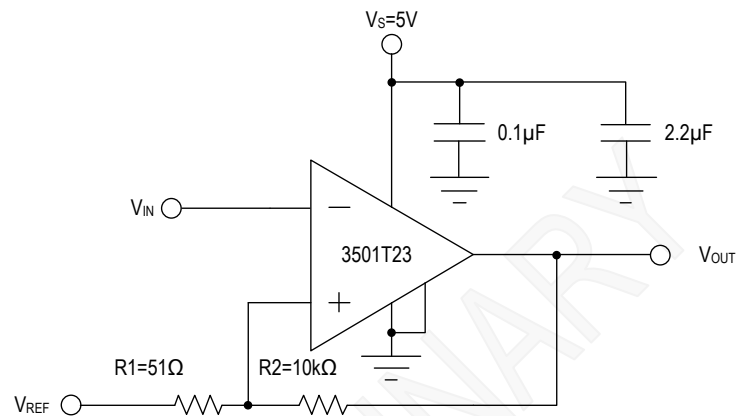

### Power Supply Recommendations

Place bypass capacitors close to the power supply pins to reduce noise coupling in from noisy or high impedance power supplies. For more information on bypass capacitor placement, see Layout Guidelines.

### Layout Guidelines

For any high speed comparator or amplifier, proper design and printed circuit board layout are necessary for optimal performance. Excess stray capacitance on the active input, or improper grounding, can limit the maximum performance of high speed circuitry. Minimizing resistance from source to the comparator input is necessary to minimize the propagation delay of the complete circuit. The source resistance, along with input and stray capacitance, creates an RC filter that delays voltage transitions at the input, and reduces the amplitude of high frequency signals. The input capacitance of the MX3501T23, along with stray capacitance from an input pin to ground, results in several picofarads of capacitance.

The location and type of capacitance used for power supply bypassing are critical to high speed comparators. The suggested 2.2uF tantalum capacitor does not need to be as close to the device as the 0.1uF capacitor, and may be shared with other devices. The 2.2uF capacitor buffers the power supply line against ripple, and the 0.1uF capacitor provides a charge for the comparator during high frequency switching.

In a high speed circuit, fast rising and falling switching transients create voltage differences across lines that would be at the same potential at DC. To reduce this effect, use a ground plane to reduce difference in voltage potential within the circuit board. A ground plane has the advantage of minimizing the effect of stray capacitances on the circuit board by providing a more desirable path for the current to flow. With a signal trace over a ground plane, at high frequency the return current (in the ground plane) tends to flow right under the signal trace. Breaks in the ground plane (as simple as through hole leads and vias) increase the inductance of the plane, making it less effective at higher frequencies. Breaks in the ground plane for necessary vias must be spaced randomly.



**Typical application**

The MX3501T23 can easily be configured as a simple and inexpensive relaxation oscillator. In the next figure, the  $R_2$  network sets the trip threshold at  $1/3$  and  $2/3$  of the supply. Because this circuit is a high speed circuit, the resistor values are low to minimize the effects of parasitic capacitance. The positive input alternates between  $1/3$  of  $V_+$  and  $2/3$  of  $V_+$ , depending on whether the output is low or high. The time to charge (or discharge) is  $0.69 \times R_1 C_1$ . Therefore, the period is  $1.38 \times R_1 C_1$ . For  $62\text{pF}$  and  $1\text{k}\Omega$  as shown in the next figure, the output is calculated to  $10.9\text{MHz}$ . An implementation of this circuit oscillator at  $9.6\text{MHz}$ . Parasitic capacitance and component tolerance explain the difference between theory and actual performance.

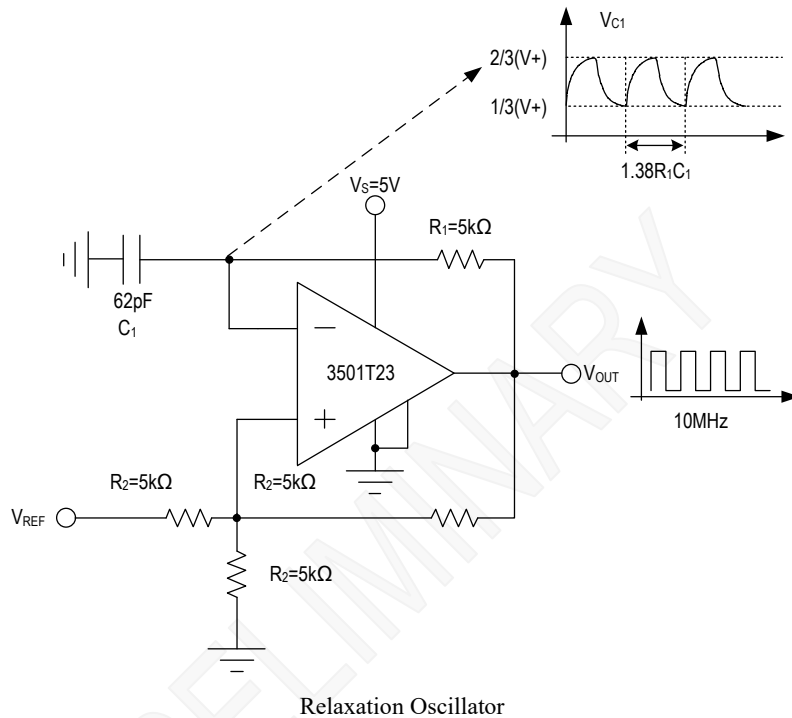

For hysteresis of  $1/3$  of  $V_+$  and threshold levels between  $1/3$  of  $V_+$  and  $2/3$  of  $V_+$ , the resistors connected to the comparator positive input must be equal in value. The resistor value must be kept low enough so it does not create additional time constant because of the input capacitor and board parasitic capacitor. The value of the charging resistor  $R_1$  must be relatively low for high frequency switching without drawing high current and affecting the output high and low level. The value of the charging capacitor must be high enough to avoid errors caused by parasitic capacitance.

For the positive input,  $V_{IN+} = 1/3 V_{OUT} + 1/3 V_+ = 1/3 V_+$ , if  $V_{OUT}$  is low and assuming  $V_{OL}$  is very close to GND. Or,  $V_{IN+} = 1/3 V_{OUT} + 1/3 V_+ = 2/3 V_+$ , if  $V_{OUT}$  is high and assuming  $V_{OH}$  is very close to  $V_+$ .

For the negative input, the capacitor charges to  $2/3 V_+$  and discharges to  $1/3 V_+$  exponentially at the same rate with a time constant of  $R_1 C_1$ .

## Package information

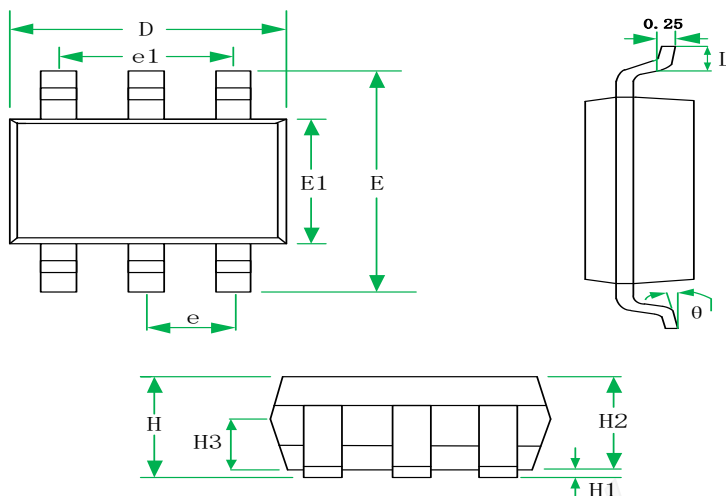

SYMBOL	MILLIMETERS			INCHES		
	MIN	NOM	MAX	MIN	NOM	MAX
H			1.45			0.057
H1	0.04		0.15	0.0016		0.0059
H2	1.00	1.10	1.20	0.039	0.043	0.047
H3	0.55	0.65	0.75	0.022	0.026	0.029
D	2.72	2.92	3.12	0.107	0.115	0.123
E	2.60	2.80	3.00	0.102	0.110	0.118
E1	1.40	1.60	1.80	0.055	0.063	0.071
e	0.95BSC			0.037BSC		
e1	1.90BSC			0.074BSC		
L	0.30		0.60	0.012		0.024
θ	0		8°	0		8°

SOT23-6 for MX3501T23

## Restrictions on Product Use

- ◆ MAXIN micro is continually working to improve the quality and reliability of its products. Nevertheless, semiconductor devices in general can malfunction or fail due to their inherent electrical sensitivity and vulnerability to physical stress. It is the responsibility of the buyer, when utilizing MAXIN products, to comply with the standards of safety in making a safe design for the entire system, and to avoid situations in which a malfunction or failure of such MAXIN products could cause loss of human life, bodily injury or damage to property.
- ◆ In developing your designs, please ensure that MAXIN products are used within specified operating ranges as set forth in the most recent MAXIN products specifications.
- ◆ The information contained herein is subject to change without notice.

PRELIMINARY